



Main

Range of product	Zelio Time
Product or component type	Optimum industrial timing relay
Component name	RE8
Time delay type	Qc
Time delay range	3...300 s
Sale per indivisible quantity	10

Complementary

Discrete output type	Relay
Contacts material	90/10 silver nickel contacts
Width pitch dimension	22.5 mm
[Us] rated supply voltage	110...240 V AC 50/60 Hz 24 V AC/DC 50/60 Hz
Voltage range	0.9...1.1 Us
Connections - terminals	Screw terminals, 2 x 1.5 mm ² flexible with cable end Screw terminals, 2 x 2.5 mm ² flexible without cable end
Tightening torque	0.6...1.1 N.m
Setting accuracy of time delay	+/- 20 % of full scale
Repeat accuracy	< 1 %
Voltage drift	< 2.5 %/V
Temperature drift	< 0.2 %/°C
Minimum pulse duration	60 ms
Reset time	50 ms
Maximum switching voltage	250 V
Mechanical durability	20000000 cycles
[Ith] conventional free air thermal current	8 A
Maximum [Ie] rated operational current	2 A DC-13 24 V at 70 °C conforming to IEC 60947-5-1/1991 2 A DC-13 24 V at 70 °C conforming to VDE 0660 3 A AC-15 24 V at 70 °C conforming to IEC 60947-5-1/1991 3 A AC-15 24 V at 70 °C conforming to VDE 0660 0.1 A DC-13 250 V at 70 °C conforming to IEC 60947-5-1/1991 0.1 A DC-13 250 V at 70 °C conforming to VDE 0660

Disclaimer: This documentation is not intended as a substitute for and is not to be used for determining suitability or reliability of these products for specific user applications

0.2 A DC-13 115 V at 70 °C conforming to IEC 60947-5-1/1991
0.2 A DC-13 115 V at 70 °C conforming to VDE 0660

Minimum switching capacity	at 12 V 10 mA
Marking	CE
Overvoltage category	III conforming to IEC 60664-1
[Ui] rated insulation voltage	250 V conforming to IEC 300 V conforming to CSA
Supply disconnection value	> 0.1 Uc
Operating position	Any position without derating
Surge withstand	2 kV conforming to IEC 61000-4-5 level 3
Power consumption in VA	13 VA at 240 V 0.9 VA at 24 V 2.5 VA at 110 V
Maximum power consumption in W	0.5 W at 24 V
Terminal description	(15-16-18)OC_OFF ALT (A1-B1)CO
Height	78 mm
Width	22.5 mm
Depth	80 mm
Net weight	0.11 kg

Environment

Immunity to microbreaks	3 ms
Standards	EN/IEC 61812-1
Product certifications	CSA GL UL
Ambient air temperature for storage	-40...85 °C
Ambient air temperature for operation	-20...60 °C
Relative humidity	15...85 % 3K3 conforming to IEC 60721-3-3
Vibration resistance	0.35 mm (f= 10...55 Hz) conforming to IEC 60068-2-6
IP degree of protection	IP20 (terminals) IP50 (casing)
Pollution degree	3 conforming to IEC 60664-1
Dielectric test voltage	2.5 kV
Non-dissipating shock wave	4.8 kV
Resistance to electromagnetic fields	10 V/m conforming to IEC 61000-4-3 level 3
Resistance to fast transients	2 kV conforming to IEC 61000-4-4 level 3
Disturbance radiated/conducted	CISPR 22 - class A CISPR 11 group 1 - class A

Packing Units

Package 1 Weight	0.093 kg
------------------	----------

Contractual warranty

Warranty	18 months
----------	-----------

Width 22.5 mm

Rail Mounting

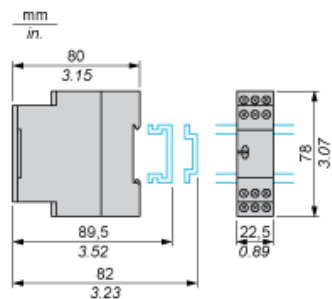

Screw Fixing

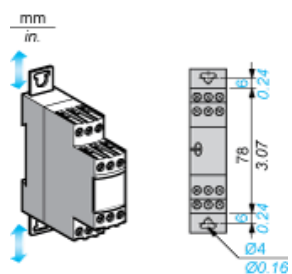

Submitted by TECO Group

Internal Wiring Diagram

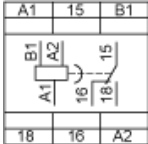

Submitted by TECO Group

Recommended Application Wiring Diagram

Control

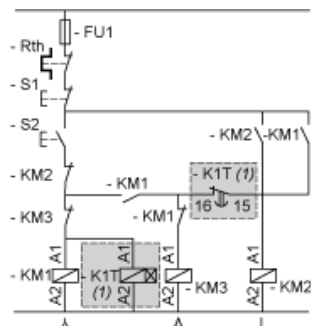

K1T Timing relay for star-delta starters.

NOTE: Correct operation of the star-delta starter associated with the relay is only possible if the wiring diagram is strictly complied with.

Power

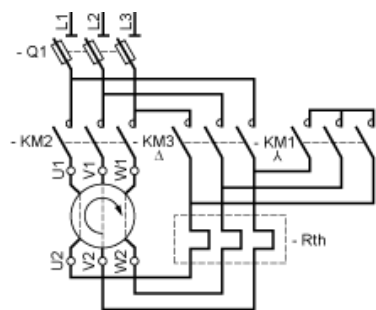

Submitted by TECO Group

Performance Curves

A.C. Load Curve 1

Electrical durability of contacts on resistive loading millions of operating cycles

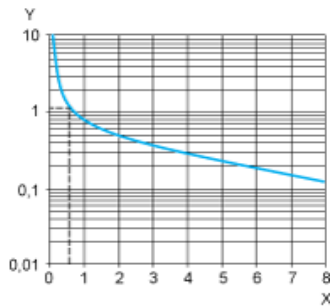

X Current broken in A
Y Millions of operating cycles

A.C. Load Curve 2

Reduction factor k for inductive loads (applies to values taken from durability curve 1).

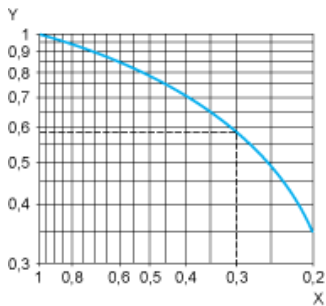

X Power factor on breaking (cos φ)
Y Reduction factor k

Example: An LC1-F185 contactor supplied with 115 V/50 Hz for a consumption of 55 VA or a current consumption equal to 0.1 A and cos φ = 0.3. For 0.1 A, curve 1 indicates a durability of approximately 1.5 million operating cycles. As the load is inductive, it is necessary to apply a reduction coefficient k to this number of cycles as indicated by curve 2. For cos φ = 0.3: k = 0.6 The electrical durability therefore becomes: $1.5 \cdot 10^6$ operating cycles \times 0.6 = 900 000 operating cycles.

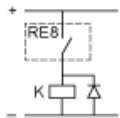

Submitted by TECO Group

D. C. Load Limit Curve

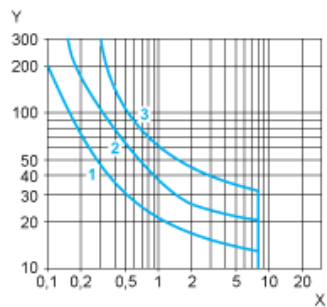

- X Current in A
- Y Voltage in V
- 1 L/R = 20 ms
- 2 L/R with load protection diode
- 3 Resistive load

Submitted by TECO Group

Function Qc: Star-Delta Timing

Description

On energisation, the star contact closes instantaneously and timing starts.

At the end of the timing period, the star contact opens.

After a 50 ms pause, the delta contact closes and remains in this position.

Function: 1 Output



Submitted by TECO Group

Legend

Relay de-energised

Relay energised

Output open

Output closed

C Control contact

G Gate

R Relay or solid state output

R1/R2 2 timed outputs

R2 inst. The second output is instantaneous if the right position is selected

T Timing period

Ta - Adjustable On-delay

Tr - Adjustable Off-delay

U Supply

RE8YG21BUTQ is replaced by:



Relay Output RE22R1QCMU

Star-Delta Timing Relay - 0.05s...300s - 24V DC / 24...240V AC - 1C/O

Qty 1

Reason for Substitution: End of life | Substitution date: 01 June 2016
