

InteliGen 200



Order code: IG3200XXBAA

Controller for parallel gen-set applications

Datasheet

Product description

- ▶ Comprehensive paralleling Gen-set controller
- ▶ Parallel operation for up to 32 Gen-sets
- ▶ Direct communication with ECU
- ▶ Remote control and monitoring
- ▶ Flexible, extendable, yet user friendly

Key features

- ▶ Multiple Island or Single Parallel to Mains applications both in one controller
- ▶ PLC support with PLC Editor and monitor
- ▶ Perfect solution for rental applications:
 - Rental timers
 - Geo-Fencing and tracking via WebSupervisor*
 - Alternative configuration
 - Droop and Emergency droop
- ▶ Load sharing and VAR sharing via CAN
- ▶ Wide communication capabilities including
 - Integrated USB for configuration
 - Isolated RS485 port on board for Modbus
 - Integrated USB Host for uploading/downloading FW/Configuration with USB key
- ▶ High accuracy of voltage and current measurement
- ▶ Cloud-based monitoring and control
- ▶ Active SMS and emails in different languages*

- ▶ Up to 5 languages in the controller
- ▶ Configurable Modbus
- ▶ Support of MODBUS RTU/TCP* or SNMP* v1/v2c
- ▶ Detailed history with up to 350 events
- ▶ Load shedding, dummy load capability
- ▶ Tier 4 Final support
- ▶ Automatic temperature based cooling/heating
- ▶ Comprehensive Gen-set protections
- ▶ Multipurpose flexible timers with full calendar
- ▶ True RMS measurement
- ▶ Low temperature version available (IG3200XXBLA)

**Available with extension module*

Application overview

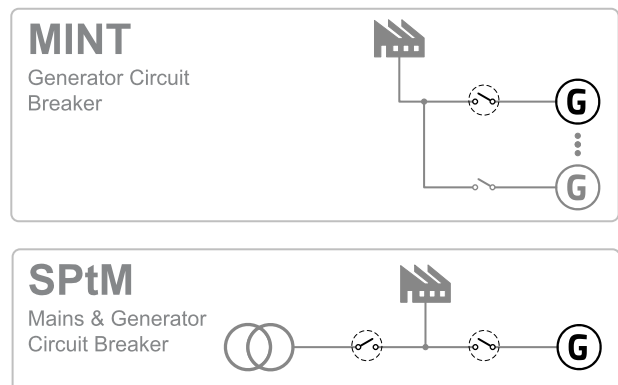

Dimensions, terminals and mounting

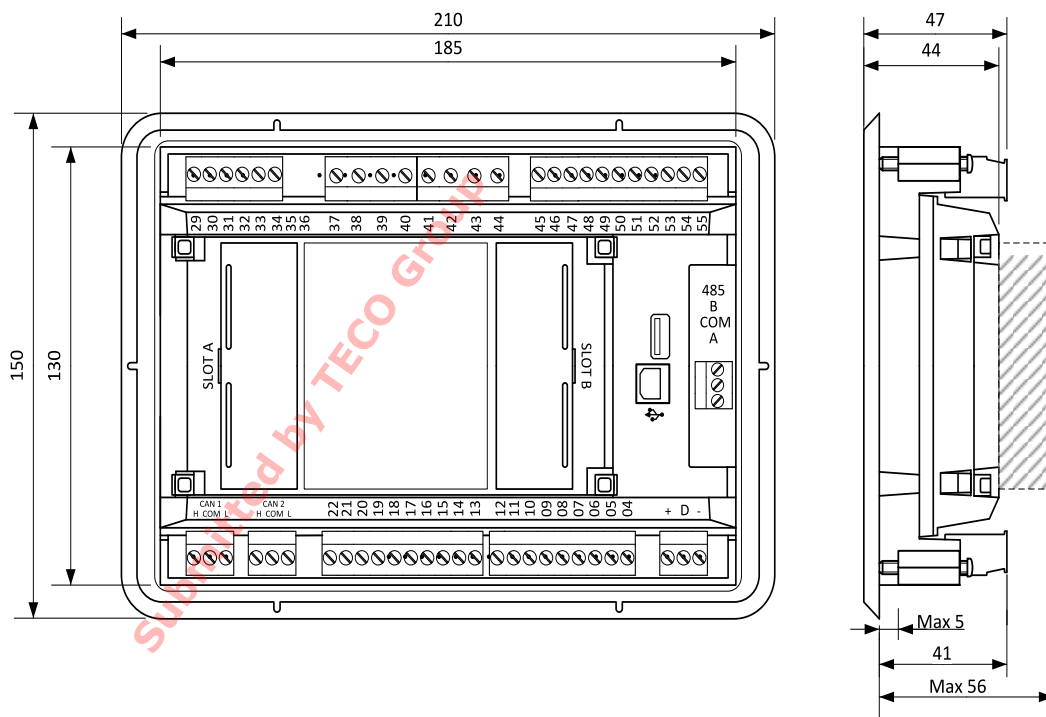
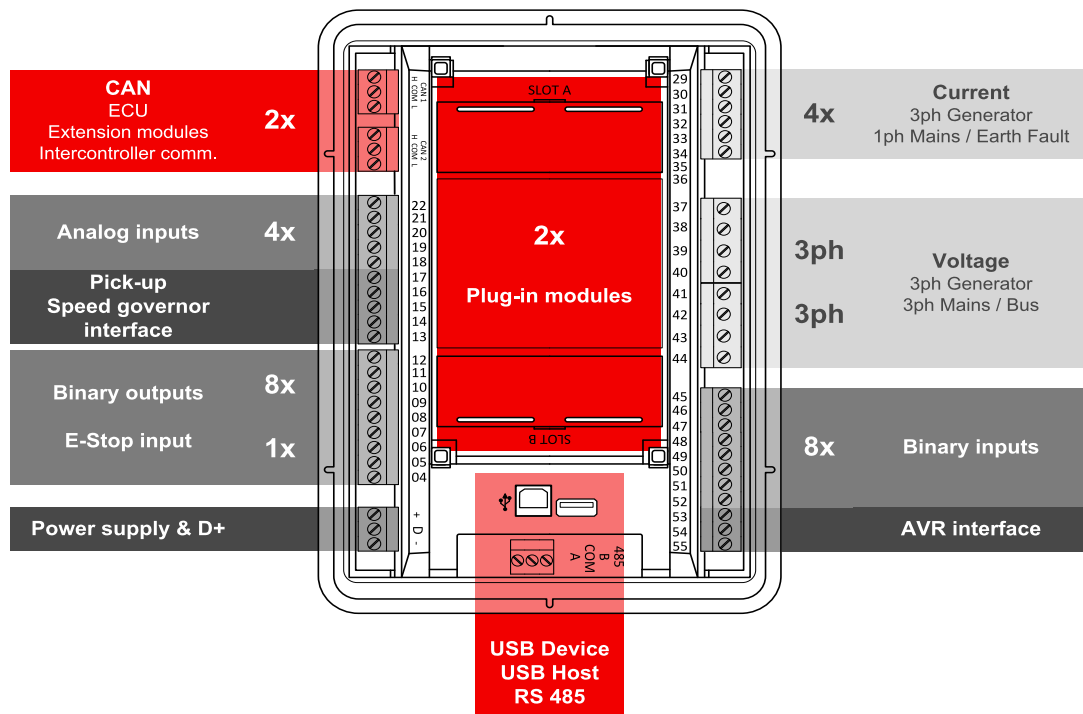

Note: The final depth of the controller depends on the selected plug-in module – it can vary between 41 mm and 56 mm. Mind also the size of connectors and cables (e.g. in case of RS232 connector, add about 60 mm more for standard RS232 connector and cable).

Power supply

Power supply range	8-36 VDC
Power consumption	320 mA / 8 VDC
	210 mA / 12 VDC
	120 mA / 24 VDC
	90 mA / 36 VDC
RTC battery	Replaceable
Fusing	Power terminal max. 4 A w/o BOUT consumption E-Stop max. 12 A
E-Stop fusing	12 A
Max. Power Dissipation	3.5 W

Operating conditions

Operating temperature	-20 °C to +70 °C
Operating temperature for Low Temp. version	-40 °C to +70 °C
Storage temperature	-30 °C to +80 °C
Protection degree (front panel)	IP 65
Operating humidity	25/55°C, RH 95%, 48hours, w/o condensation
Vibration	5-25 Hz, ± 1.6 mm
	25-100 Hz, a = 4 g
Shocks	a = 500 m/s ²
Surrounding air temperature rating 70 °C Suitable for pollution degree 2	
Heat radiation	9 W

D+ terminal

Max. output current	250 mA
Charging fail threshold	80 % of U _{supply}

Voltage measurement

Measurement inputs	3ph-n Gen voltage , 3ph-n Mains
Measurement range	277 V / 480 V AC (EU)
	346 V / 600 V AC (US/Canada)
Linear measurement and protection range	381 V / 660 V
Accuracy	1 %
Frequency range	40-70 Hz (accuracy 0.1 Hz)
Input impedance	0.72 MΩ ph-ph , 0.36 MΩ ph-n

Voltage regulator output

Protection	Isolated
Type	max ±10 VDC

Speed governor output

Output Type	±10 VDC or 5 V @ 500 Hz, PWM selectable by jumper
Protection	Non-isolated

Display

Type	Build-in monochromatic 3.2"
Resolution	132 × 64 px

Communications

USB port	non-isolated
USB Device	Non-isolated type B connector
USB Host	Non-isolated type A connector
RS 485	RS485
CAN 1 + CAN 2	250 / 50 kbps, isolated, nominal impedance 120 Ω

Current measurement

Measurement inputs	3ph Gen current, 1ph Mains
Measurement range	5 A
Max. allowed current	10 A
Accuracy	1.5 % for full temperature range (1 % from 0 °C to 50 °C)
Input impedance	<0.1 Ω

E-Stop

Dedicated terminal for E-Stop input Physically disconnects binary outputs 1 & 2 from power	
---	--

Binary inputs

Number	8, non-isolated
Close/Open indication	0-2 VDC close contact 6-36 VDC open contact

Binary outputs

Low current	6 low current output, non-isolated BO 3-8 = 0.5 A switching to positive supply terminal
High current	2 high current output, non-isolated BO 1, 2 = 4 A switching to positive supply terminal

Analog inputs

Number	4, Resistive
Resolution	0.1 Ω
Range	0-2500 Ω
Input impedance	170 Ω
Accuracy	±2 % from value in range above ±1.5 kΩ in range 2.5-15 kΩ

Magnetic pickup

Voltage input range	4 Vpk-pk to 50 Vpk-pk in range 4 Hz to 1 kHz 6 Vpk-pk to 50 Vpk-pk in range 1 to 5 kHz 10 Vpk-pk to 50 Vpk-pk in range 4 to 10 kHz
Frequency input range	4 Hz to 10 kHz
Frequency measurement tolerance	0.2 % from range 10 kHz

Available Extension modules

Product	Description	Order code
CM-4G-GPS	For SMS and GPS info	CM14GGPSXBX
CM-Ethernet	Ethernet interface	CM2ETHERXBX
CM-GPRS	For SMS	CM2GPRSXXBX
CM-RS232-485	Dual port interface	CM223248XBX
EM-BIO8-EFCP	8 additional binary inputs/outputs	EM2BIO8EXBX

Note: Maximally 2 plug-in modules can be connected in the same time.

Available CAN modules

Product	Description	Order code
Inteli AIN8	CAN module with 8 analog inputs	I-AIN8
Inteli AIN8TC	CAN module with 8 analog inputs dedicated for thermocouple sensors only.	I-AIN8TC
Inteli IO8/8	CAN module with 8 binary inputs and 8 binary outputs	I-IO8/8
IGL-RA15	CAN remote annunciator with 15 LEDs	EM2IGLRABAA
IGS-PTM	CAN module with 8 binary inputs, 8 binary outputs, 4 analog inputs and 1 analog output	IGS-PTM

Note: Maximally 5 CAN modules can be connected in the same time.

Functions and protections

Support of functions and protections as defined by ANSI (American National Standards Institute):



Description	ANSI code	Description	ANSI code
Master unit	1	Voltage unbalance	47
Stopping device	5	Incomplete sequence relay	48
Multi-function device	11	Overcurrent	50/50TD
Overspeed	12	Earth fault**	50G
Underspeed	14	Overcurrent IDMT	51
Starting-to-running transition contractor	19	AC circuit breaker	52
Synchronizing-check	25	Overvoltage	59
Thermal relay	26	Pressure switch	63
Undervoltage	27	Liquid level switch	71
Annunciator	30	Alarm relay***	74
Overload(real power)	32P	Reclosing relay	79
Reverse power	32R	Overfrequency	81O
Master sequence device	34	Underfrequency	81U
Excitation loss	40	ROCOF	81R
Unit sequence starting *	44	Auto selective control/transfer	83
Current unbalance	46		

*MINT

**Extension module EM-BIO8-EFCP required

*** extension module IGL-RA15 required

Certifications and standards

<ul style="list-style-type: none"> ▶ EN 61000-6-2 ▶ EN 61000-6-4 ▶ EN 61010-1 ▶ EN 60068-2-1 (-20 °C/16 h for std, -40 °C/16 h for LT version) ▶ EN 60068-2-2 (70 °C/16 h) 	<ul style="list-style-type: none"> ▶ EN 60068-2-6 (2÷25 Hz / ±1,6 mm; 25÷100 Hz / 4.0 g) ▶ EN 60068-2-27 (a=500 m/s²; T=6 ms) ▶ EN 60068-2-30:2005 25/55°C, RH 95%, 48hours ▶ EN 60529 (front panel IP65, back side IP20) ▶ UL 6200 	 
---	---	--

